

HEAVY-DUTY LARGE VOLUME STORAGE TANKS MODEL HD CUSTOM BUILT

Large volume tanks are designed for storing potable water.

FEATURES

SIZES FROM 120 TO 4,000 GALLONS

All tanks are constructed to the requirements of the ASME Code. These ASME Code tanks are available at 125 and 150 PSI working pressure. Consult factory for tanks with special configurations.

LINING AND COATINGS

Each lining and coating has particular capabilities and limitations. Thorough investigation on the service life of steel tanks with protective coatings or linings has led to the recommendation of the following linings:

- Glass Lined — All internal surfaces exposed to water are glass lined per ASME HLW Code procedures.
- Cement Lined — Cement lining consists of a specially formulated cement applied over the interior of the vessel. Cement lined tanks are recommended when storing water at 180°F or higher.
- Epoxy Lined — The application of specially formulated epoxy makes this lining suitable for cold or hot water storage.

Please consult the factory for recommendations on the uses of linings for specific applications. All tanks receive one prime coat of paint on external surface.

CATHODIC PROTECTION

Glass lined and epoxy tanks are furnished with anodes designed for maximum protection.

CUSTOM TANK OPENINGS

All tanks will be supplied with the fittings located as indicated on the drawings unless specified otherwise. Custom tank opening sizes and locations can be provided to your specification.

INSPECTION OPENINGS

- 12" x 16" manhole or 4" x 6" handhole are available as options on diameters 36" and below.
- Two 2" ASME inspection openings are standard on tanks 36" diameter and below.
- 12" x 16" manhole is standard on tanks with 42" diameters and above.

TANK OPTIONS

- Manholes / Handholes
- Additional / Custom Tank Openings
- Lifting Lugs
- Horizontal Tank Saddles
- Factory Jacketing and Insulation
- Tube bundles
- Cement and Epoxy Linings

Attention: Significant changes have been made to some models. Please note that this spec sheet refers specifically to models manufactured in Lebanon, TN

MODELS
HD-20-120 THROUGH
HD-72-4000

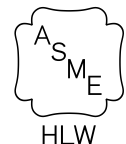
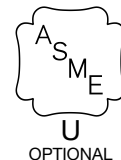



COMMERCIAL STORAGE TANKS

STORAGE TANK SELECTION

Model Number	Gallons	Dimensions			Shipping Weight (lbs.)		
		Diameter	Vertical Height	Horizontal Length	125 psi	150 psi	Cement Lined
HD*24-120A	118	24"	64"	60"	368	368	-
HD*24-140A	141	24"	76"	72"	428	428	-
HD*24-200A	188	24"	100"	96"	556	556	-
HD*24-250A	235	24"	124"	120"	684	684	-
HD*28-175A	175	28"	65"	-	353	353	-
HD*28-200A	200	28"	76"	-	488	488	-
HD*30-150A	147	30"	52"	48"	400	400	695
HD*30-185A	184	30"	64"	60"	468	468	812
HD*30-220A	220	30"	76"	72"	548	548	958
HD*30-250A	257	30"	87"	83"	628	628	1,103
HD*30-300A	294	30"	100"	96"	701	701	1,242
HD*30-375A	367	30"	124"	120"	868	868	1,540
HD*36-275A	265	36"	64"	60"	577	577	995
HD*36-325A	318	36"	76"	72"	673	673	1,173
HD*36-400A	370	36"	87"	83"	770	770	1,343
HD*36-425A	423	36"	100"	96"	866	866	1,513
HD*36-500A	528	36"	124"	120"	1,058	1,058	1,861
HD*42-450A	432	42"	76"	72"	795	909	1,385
HD*42-500A	504	42"	88"	84"	908	1,050	1,587
HD*42-600A	576	42"	100"	96"	1,020	1,190	1,790
HD*42-750A	720	42"	124"	120"	1,245	1,470	2,195
HD*42-900A	864	42"	148"	144"	1,470	1,751	2,601
HD*42-1000A	1,008	42"	172"	168"	1,695	2,031	3,006
HD*48-700A	658	48"	88"	84"	1,346	1,346	2,124
HD*48-750A	752	48"	100"	96"	1,507	1,507	2,392
HD*48-950A	940	48"	124"	120"	1,828	1,828	2,918
HD*48-1150A	1,128	48"	148"	144"	2,150	2,150	3,444
HD*48-1300A	1,315	48"	172"	168"	2,471	2,471	3,970
HD*48-1500A	1,503	48"	196"	192"	2,793	2,793	4,505
HD*54-1000A	951	54"	100"	96"	1,721	1,972	2,729
HD*54-1200A	1,189	54"	124"	120"	2,083	2,423	3,320
HD*54-1450A	1,427	54"	148"	144"	2,451	2,881	3,919
HD*54-1700A	1,665	54"	172"	168"	2,807	3,326	4,511
HD*54-1900A	1,903	54"	196"	192"	3,168	3,777	5,102
HD*54-2150A	2,141	54"	220"	216"	3,530	4,228	5,701
HD*60-1500A	1,469	60"	124"	120"	2,784	3,221	4,177
HD*60-1750A	1,763	60"	148"	144"	3,267	3,823	4,913
HD*60-2000A	2,056	60"	172"	168"	3,749	4,425	5,658
HD*60-2400A	2,350	60"	196"	192"	4,231	5,026	6,394
HD*60-2650A	2,644	60"	220"	216"	4,713	5,628	7,130
HD*72-2100A	2,115	72"	124"	120"	3,416	3,904	5,104
HD*72-2500A	2,538	72"	148"	144"	3,995	4,627	5,995
HD*72-3000A	2,961	72"	172"	168"	4,575	5,350	6,885
HD*72-3400A	3,384	72"	196"	192"	5,154	6,073	7,767
HD*72-4000A	3,807	72"	220"	216"	5,733	6,795	8,658

Specify Horizontal or Vertical installation H or V (after the HD)

* For Horizontal e.g. (HDH48-1500A) or Vertical e.g. (HDV48-1500A)

For Jacketed models, the J will follow the orientation: HDVJ48-1500A. For foam insulation, O represents Outdoor: HDVO48-1500A

For linings other than glass, use the suffix after the number and the A - HDHJ42-1000AE for and Epoxy lined or HDHJ42-100AC for Cement lined. U = Unlined.

For 150 PSI ASME working pressure, insert M at the end - HDV42-1000AM

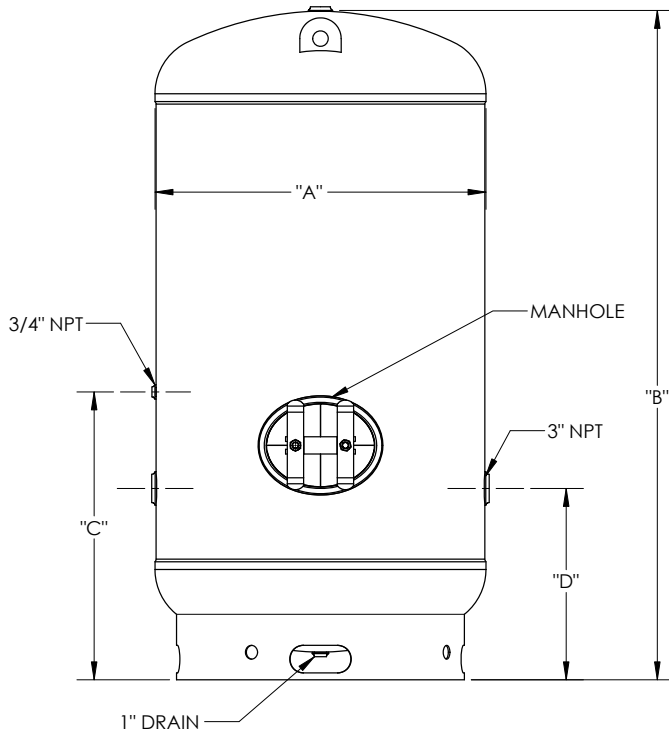

Diameter	C	D
24	16.75	11
28	17.375	11.62
30	31.875	15.875
36	33.375	17.375
42	34.875	18.875
48	36.875	20.875
54*	38.375	22.375
60	39.875	24.5
72	42.375	27

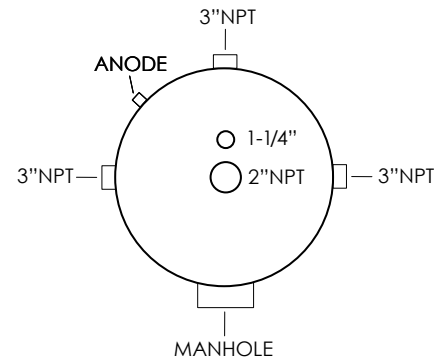

NOTE:
SPECIFY FOR HORIZONTAL OR VERTICAL INSTALLATION.
2 each 2" ASME inspection openings are standard on tanks 36" diameter and below.
12"x16" ASME inspection openings are standard on tanks with 42" diameters and above.

Diameter	C	D
24	24.625	6
30	26.5	6
36	28	12
42	29.5	12
48	31.5	12
54	33	12
60	34.5	12
72	37	12

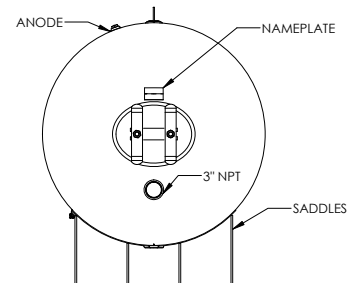
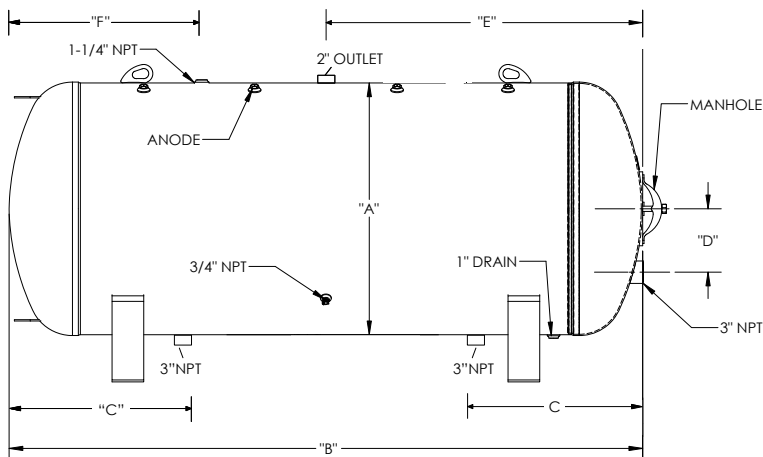

30" - 72" DIAMETER HORIZONTAL TANKS

TANK SADDLE DIMENSIONS

Tank Diameter
30 36 42 48 54 60 72

A 21" 25" 29" 34" 48" 52" 62"

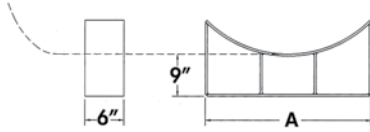

NOTE: Alternate saddle heights are available.
(Consult factory)

TANK SADDLES

A.O. SMITH PART NO.	SADDLE DESCRIPTIONS
100170345	SADDLE, TANK, 24", 9" CLR, P-1
100170349	SADDLE, TANK, 30", 9" CLR, P-1
100170338	SADDLE, TANK, 28", 9" CLR, P-1
100170352	SADDLE, TANK, 36", 9" CLR, P-1
100170355	SADDLE, TANK, 42", 9" CLR, P-1
100170358	SADDLE, TANK, 48", 9" CLR, P-1
100170361	SADDLE, TANK, 54", 9" CLR, P-1
100170365	SADDLE, TANK, 60", 9" CLR, P-1
100170371	SADDLE, TANK, 72", 9" CLR, P-1

FACTORY INSULATION OPTIONS

Factory Jacketed and Insulation

- **INSULATION** — Entire tank is surrounded with insulation.
- **CABINET** — Heavy gauge painted steel.
- Adds 4" to the round jacketed and 6" to the square jacketed diameter of the tank, and 2" to the height.



OUTDOOR FOAM INSULATION

- **INSULATION** — Entire tank is sprayed with minimum of 2" high-density polyurethane foam insulation that forms a watertight jacket that is approved for outdoor use.
- Adds 4" to the diameter of the tank, and 2" to the height.

Note: Minimum foam insulation thickness is 2"; however, since tank is hand sprayed, insulation thicknesses may be greater in some areas giving the finished tank an uneven but watertight surface.

SUGGESTED SPECIFICATION

SAMPLE SPECIFICATION FOR CUSTOM-LINE STORAGE TANKS

When jacketed or insulated these models meet or exceed the thermal efficiency and standby loss requirements of ASHRAE 90.1b (current standard).

ASME storage tank to be A. O. Smith Custom-Line model _____. Capacity to be _____ gallons with a diameter of _____ inches. Tank(s) shall be constructed and stamped according to ASME specifications for _____ psi working pressure. Manhole (12"x16"), handhole (4x6) or inspection openings (2-2") shall be installed in accordance with ASME code requirements and manufacturer(s) standard practice. Tank to be constructed of (carbon steel) _____. Lining shall be (glass, epoxy, cement) _____. Tank(s) lined with (glass, cement, epoxy) _____ lining shall be equipped with the number and size of anode rod(s) sufficient to provide adequate protection for the tank lining. Tank shall be (vertical, horizontal) _____ design and provided with (four) _____ ring base, _____ saddles.

For technical information, call 800-527-1953. A. O. Smith Corporation reserves the right to make product changes or improvements without prior notice.